



RADEX®-N

Steel lamina coupling

RIGIFLEX®-N

Steel lamina coupling

RIGIFLEX®-HP

High-performance steel lamina coupling

Made for Motion



Table of contents



RADEX®-N	
Steel lamina coupling	121
Coupling selection steel lamina coupling	123
Description of coupling	125
General information	126
Types and applications	127
Technical data	128
Standard types	130
Customized types	132
Standard series NANA 3 for pump drives according to API 610	133
Corrosion-resistant type for big shaft distance dimensions	134
RIGIFLEX®-N	
Steel lamina coupling	
Description of coupling	135
Technical data	136
Type A	138
NEW RIGIFLEX®-HP	
High Performance - Steel lamina coupling	
Coupling selection RIGIFLEX®-HP	139
Type C	140
Type L	141
Technical data of RIGIFLEX®-HP	142

Coupling selection steel lamina coupling

Description	Symbol	Definition or explanation
Rated torque of coupling	T_{KN}	Torque which can be transmitted continuously over the entire speed range of the coupling.
Vibratory torque of coupling	T_{KW}	Torque amplitude of the permissible periodic torque fluctuation with a frequency of 10 Hz and a basic load of T_{KN} or pulsating load up to T_{KN} .
Maximum torque of coupling	T_{Kmax}	Torque which can be transmitted during the entire life of the coupling $\geq 10^5$ times as pulsating load or 5×10^4 times as alternating load.

Guidelines for operating factor S_B	
Machine	S_B
Construction machinery	2,0
Agitators	1,0 - 2,0
Centrifuges	1,5
Conveyors	2,0
Elevators	2,0
Fans/Blowers	1,5
Generators	1,5
Calanders	2,0
Grinders, crushers	2,5
Textile machinery	2,0
Rolling mills	2,5
Woodworking machinery	1,5
Mixers and extruders	2,0
Stamps, presses	2,5
Machine tools	2,0
Grinders	2,5
Packaging machines	1,0
Roller drives	2,5
Piston pumps	2,5
Centrifugal pumps	1,5
Piston compressors	2,5
Turbo compressors	2,0

1. Permissible displacements:

ΔK_a : Permissible axial displacement

ΔK_w : Permissible angular displacement

ΔK_r : Permissible radial displacement

Steel lamina couplings are selected in a way that the maximum permissible angular displacement ΔK_w may be compensated by each lamina set. Consequently the maximum possible angular displacement of two shafts combined with each other is $2 \cdot \Delta K_w$. The maximum angular displacement for each lamina set is listed in the table "Technical data".

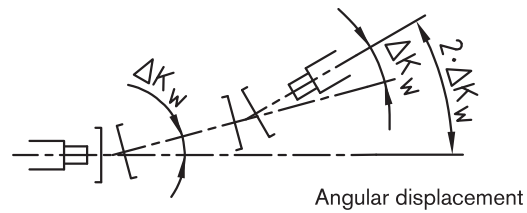

The permissible radial displacement ΔK_r with distance g of the coupling elements is

$$\Delta K_r = g \cdot \tan(\Delta K_w)$$

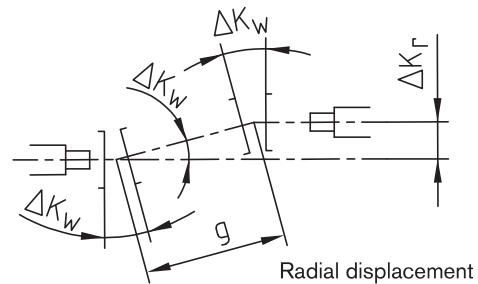

The table "Technical data" (RADEX®-N page 126/127 and RIGIFLEX®-N page 134/135) shows the max. permissible radial displacements ΔK_r for every size and type based on the given standard lengths of the spacers as well as the permissible angular displacement ΔK_w of the coupling elements.

The max. permissible axial displacements ΔK_a for every size and type are also mentioned in the table "Technical data".

The figures of the permissible displacements indicated are dependent on each other!

With an increasing axial displacement ΔK_a the permissible angular displacement ΔK_w decreases and thus the radial displacement ΔK_r . (See our mounting instructions at www.ktr.com).

Coupling selection steel lamina coupling

Selection of the coupling size

2. Drives without periodical torsional vibrations

For example centrifugal pumps, fans, screw compressors, etc. The coupling selection requires that the rated torque T_{KN} and the maximum torque T_{Kmax} are reviewed.

2.1 Loading by rated torque

Taking into account the operating factor S_B , directional factor S_R and temperature factor S_t , the permissible rated speed must be at least as big as the rated torque T_N of the machine.

The rated torque T_{KN} of the coupling is:

$$T_{KN} \geq T_N \cdot S_B \cdot S_t \cdot S_R$$

T_N = Torque of the machine

S_B = Operating factor (see table on page 123)

S_R = Factor of direction = 1,00 same torque direction = 1,70 torque direction switching

S_t = Operating temperature Temperature factor

°C	-30	0	+150	+200	+230	+270
Factor	1,00	1,00	1,00	1,10	1,25	1,43

2.2 Loading by torque shocks

The permissible maximum torque T_{Kmax} of the coupling must be at least as big as the sum of the peak torque T_S and rated torque T_N of the machine taking into account the operating factor S_B , temperature factor S_t and directional factor S_R . This applies in case that the rated torque of the machine is superimposed by a shock (e. g. starting of the engine). For drives with A. C. motors and big masses on the load side we would recommend calculations by our simulation program (please consult with us).

$$T_{Kmax} \geq (T_N + T_S) \cdot S_t \cdot S_R$$

T_S = Peak torque

Selection of the coupling size

3. Drives with periodical torsional vibrations

For drives subject to dangerous torsional vibrations (e. g. diesel engines, piston compressors, piston pumps, generators, etc.) it is necessary to perform a torsional vibration calculation (please consult with us).

3.1 Loading by rated torque

Taking into account the operating factor S_B , directional factor S_R and temperature factor S_t , the permissible rated speed must be at least as big as the rated torque T_N of the machine.

The rated torque T_{KN} of the coupling is:

$$T_{KN} \geq T_N \cdot S_B \cdot S_t \cdot S_R$$

T_N = Torque of the machine

S_B = Operating factor (see table on page 123)

S_R = Factor of direction = 1,00 same torque direction = 1,70 torque direction switching

S_t = Operating temperature Temperature factor

°C	-30	0	+150	+200	+230	+270
Factor	1,00	1,00	1,00	1,10	1,25	1,43

3.2 Passing through resonance

The peak torque T_{SR} arising while passing through resonance must not exceed the permissible maximum torque of the coupling T_{Kmax} .

$$T_{Kmax} \geq T_{SR}$$

3.3 Loading by vibratory torque

The permissible vibratory torque of the coupling T_{KW} must not be exceeded by the maximum periodical vibratory torque of the machine T_W .

$$T_{KW} \geq T_W$$

Description of coupling

The RADEX®-N is a backlash-free, torsionally rigid and maintenance-free all-steel coupling. The laminae that are extremely rigid in sense of rotation are made of high-strength, stainless spring steel and enable a compensation for high displacements with low restoring forces. By reason of the all-steel design the RADEX®-N can be used in drives with temperatures of up to 280 °C.



FEM-optimized lamina shape

The steel lamina sets made of stainless spring steel were developed on the basis of FEM calculations. Taking into account the necessary possibilities of displacements of the coupling the optimum shape regarding torque transmission and torsional rigidity was aimed at. The fitted shape of the steel laminae on the outside diameter is the result of this optimization calculation.

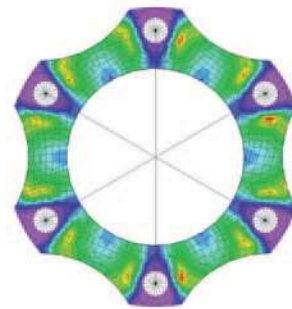

Lamina sets with dowel screws

The „heart“ of the steel lamina coupling are the lamina sets and their connection to the hubs or spacers. High-strength, special dowel screws that are alternately screwed to hubs and spacer enable a combination of frictional engagement and positive locking. Thus a high power density with at the same time ease of displacement and low restoring forces is ensured. Due to the special design of the RADEX®-N components the lamina sets are prestressed „artificially“. Hereby the torsional rigidity is increased by approx. 30 % and at the same time the well-known problem regarding the axial vibrations of the spacer is prevented.

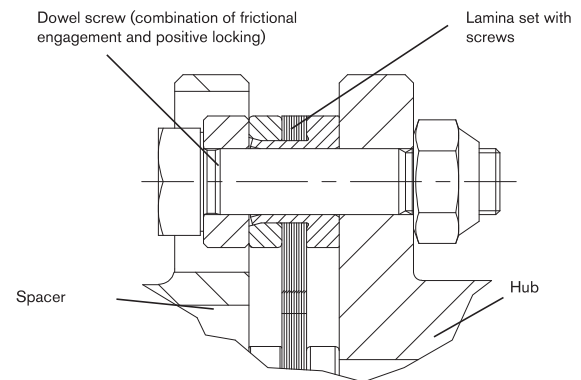

Use in explosive applications

RADEX®-N couplings are suitable for power transmission in drives in hazardous areas. The couplings are certified and confirmed according to EC standard 94/9/EC (ATEX 95) as units of category 2G/2D and thus suitable for the use in hazardous areas of zone 1, 2, 21 and 22. With the use in explosive areas clamping ring hubs (clamping hubs without feather key for category 3 only) have to be selected such that there is a safety factor of $s = 2$ between the peak torque of the unit including all operating parameters and the friction and rated torque of the coupling. You will find further details about this subject at www.ktr.com.



General information

Assembly and operating advice

(Please see our mounting instructions KTR standard 471 10 at www.ktr.com.) For the assembly it is important to make sure that the lamina sets are assembled free from distortion in axial direction. If the finish bore is machined by the customer, the concentric and axial running tolerances have to be observed (see sketch).

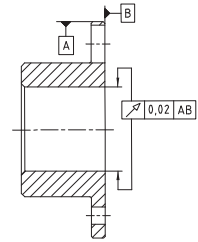

Installation:

RADEX®-N couplings are designed for horizontal installation. For vertical installation the spacer might have to be supported (see sketch). Please consult with us.

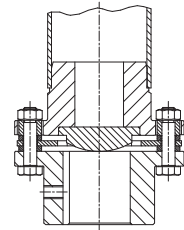

Delivery condition

RADEX®-N couplings are supplied as individual parts (can be delivered assembled on request). The hubs can be supplied unbored or with finish bore and feather keyway or with a frictionally engaged shaft-hub-connection. The shaft-hub-connection needs to be inspected by the customer (if necessary, please consult with KTR).



Balancing:

On request of the customer the RADEX®-N couplings can be balanced. For usual applications this is not necessary due to the accurate machining of the coupling. Please consult with KTR, if necessary.

Safety regulations:

The coupling must be selected in a way that the permissible coupling load is not exceeded in any operating condition. For that purpose a comparison between the actual loads and the permissible coupling characteristics has to be performed. The customer must protect rotating parts from accidental contact (Safety of Machines DIN EN 292 part 2). Please take precautions that there is a sufficient coupling protection in case of a fracture of the coupling caused by overload.

Hub designs

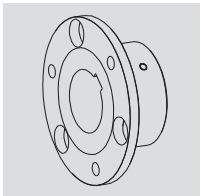

Design 1.0 Hub with feather keyway and thread for setscrews

Positive locking torque transmission, permissible torque depending on the permissible surface pressure. Not suitable as backlash-free torque transmission with heavily reversing operation.

Design 1.1 hub without keyway, with fixing screw

Non-positive torque transmission for crimped and bonded connections (no ATEX release)

Design 1.2 Hub without feather keyway, without thread for setscrews

Non-positive torque transmission for crimped and bonded connections (no ATEX release)

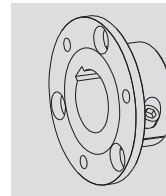

Design 2.5 clamping hub with two slots without feather keyway

Frictionally engaged, backlash-free shaft-hub-connection. Transmittable torques depending on bore diameter. Only permissible for ATEX cat. 3.

Design 2.6 clamping hub with two slots with feather keyway

Positive locking shaft-hub-connection with additional frictionally engaged operation. The frictionally engaged operation prevents or reduces reverse backlash.

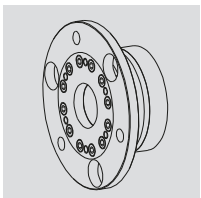

Design 6.0 clamping ring hub

Integrated frictionally engaged shaft-hub-connection for the transmission of higher torques. Clamping screws on lamina side. Transmittable torques depending on bore diameter. Suitable for high speeds.

Design 6.5 clamping ring hub

Integrated frictionally engaged shaft-hub-connection for the transmission of higher torques. Clamping screws externally. Transmittable torques depending on bore diameter. Suitable for high speeds.

Types and applications

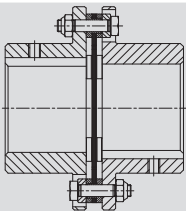
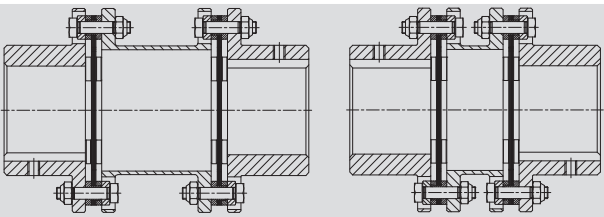
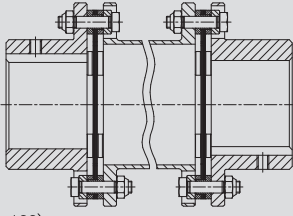
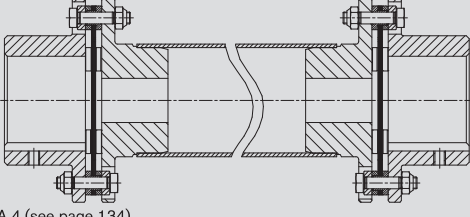
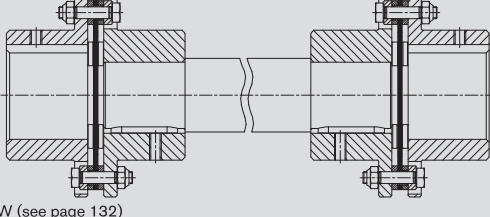
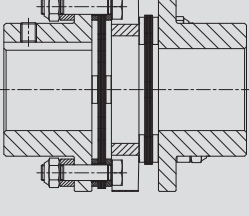
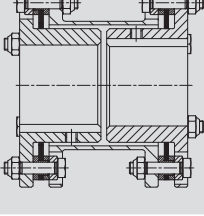
Type	Characteristics	Applications
 <p>Type NN (see page 130)</p>	<ul style="list-style-type: none"> ● Single cardanic design ● Only angular and axial displacement permissible ● High torsional rigidity ● Compact dimensions 	<ul style="list-style-type: none"> ● Mixers ● Agitators ● Immersion pumps ● Fans ● Applications with high radial load
 <p>Type NANA 1 / NANA 2 (see page 132)</p>	<ul style="list-style-type: none"> ● Double cardanic design ● Compensating for high misalignment with low restoring forces ● Standard spacers available from stock 	<ul style="list-style-type: none"> ● Paper machines ● Printing and processing machines ● Conveyors ● Steel mills ● Generators ● Grinding machines
 <p>Type NANA 3 (see page 133)</p>	<ul style="list-style-type: none"> ● Double cardanic design ● Spacers adapted to standard dimensions of pumps ● Radial assembly, no shifting of the machine required ● Available according to API 610 	<ul style="list-style-type: none"> ● Process pumps ● Water pumps ● Pumps according to API standard ● Turbines ● Compressors
 <p>Type NANA 4 (see page 134)</p>	<ul style="list-style-type: none"> ● Spacers can be determined by the customer ● Maximum shaft distance dimension up to approx. 6 m ● Welded intermediate pipes for high torsional rigidity 	<ul style="list-style-type: none"> ● Foil and paper machines ● Pallet and conveyor systems ● Robotic palletizers ● Test benches ● Cooling towers/blowers
 <p>Type NNW (see page 132)</p>	<ul style="list-style-type: none"> ● Spacers can be determined by the customer ● Coupling consisting of 2 times type NN with intermediate shaft ● For drives with relatively low speeds 	<ul style="list-style-type: none"> ● Low speed drives with big shaft distance dimensions ● Agitators ● Crushers ● Presses ● Packaging machines
 <p>Type NNZ (see page 131)</p>	<ul style="list-style-type: none"> ● Compact double cardanic design ● Cannot be radially assembled ● With intermediate disk ● Ideal for replacement of curved-tooth gear couplings from steel ● Standard type up to size 70 	<ul style="list-style-type: none"> ● Robotics ● Paper machines and inserters ● Machine tools ● Packaging machines ● Test benches
 <p>Type NENE 1 (see page 131)</p>	<ul style="list-style-type: none"> ● With reduced hubs ● Compact double cardanic design ● Spacer cannot be radially assembled ● Variable spacer length 	<ul style="list-style-type: none"> ● Applications with short shaft distance dimensions ● Replacement for curved-tooth gear couplings from steel

RADEX®-N
RIGIFLEX®-N
RIGIFLEX®-HP

Technical data

The following lamina types are distinguished with RADEX®-N

Size 20 – 50
(4 hole lamina)

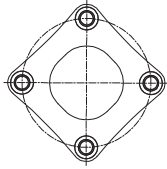

Size 60 – 135
(6 hole lamina)

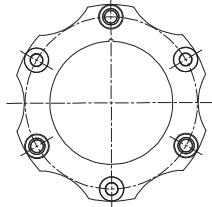

Size 136 – 336
(6 hole lamina)

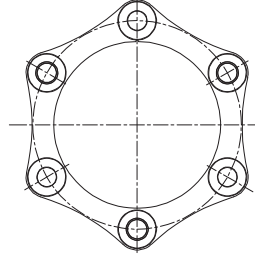

Size 138 – 338
(8 hole lamina)

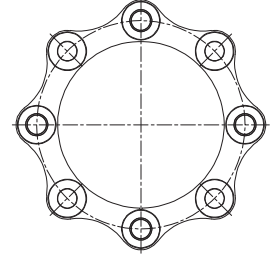

Torques and displacements

Size	Lamina type	Torques [Nm] ¹⁾			Angular [°] each lamina	Permissible displacements ²⁾			
		TKN	TK max	TKW		Axial [mm]		Radial [mm]	
						NN	NANA 1/ NANA2/ NNZ	NANA 1	NANA 2/NNZ
20	4 hole lamina	15	30	5	1,0	0,60	1,2	1,0	0,2
25		30	60	10	1,0	0,80	1,6	1,0	0,2
35		60	120	20	1,0	1,00	2,0	1,1	0,3
38		120	240	40	1,0	1,20	2,4	1,2	0,3
42		180	360	60	1,0	1,40	2,8	1,2	0,4
50		330	660	110	1,0	1,60	3,2	1,5	0,4
60		690	1380	230	1,0	1,00	2,0	1,5	0,8
70		1100	2200	370	1,0	1,10	2,2	1,8	0,4
80		1500	3000	500	1,0	1,30	2,6	2,1	1,2
85		2400	4800	800	1,0	1,30	2,6	2,2	1,2
90	4500	9000	1500	1,0	1,00	2,0	2,2	1,1	
105	5100	10200	1700	1,0	1,20	2,4	2,4	1,4	
115	9000	18000	3000	1,0	1,40	2,8	2,5	1,5	
135	6 hole lamina	12000	24000	4000	1,0	1,75	3,5	3,8	-
136		17500	35000	8750	0,7	1,85	3,7		
156		25000	50000	12500	0,7	2,10	4,2		
166		35000	70000	17500	0,7	2,25	4,5		
186		42000	84000	21000	0,7	2,40	4,8		
206		52500	105000	26250	0,7	2,60	5,2		
246		90000	180000	45000	0,7	3,00	6,0		
286		150000	300000	75000	0,7	3,35	6,7		
336		210000	420000	105000	0,7	3,75	7,5		
138		23000	46000	11500	0,5	1,30	2,6	Depending on distance dimension E	
158		33000	66000	16500	0,5	1,40	2,8		
168	8 hole lamina	45000	90000	22500	0,5	1,50	3,0		
188		56000	112000	28000	0,5	1,60	3,2		
208		70000	140000	35000	0,5	1,75	3,5		
248		120000	240000	60000	0,5	2,00	4,0		
288		200000	400000	100000	0,5	2,40	4,5		
338		280000	560000	140000	0,5	2,50	5,0		

Permissible speeds and torsional stiffness figures

Size	Max. speed [rpm] (higher speeds on request)	Torsion spring rigidity x 10 ⁶ [Nm/rad] per lamina set	Size	Max. speed [rpm] (higher speeds on request)	Torsion spring rigidity x 10 ⁶ [Nm/rad] per lamina set
20	20000	0,017	156	3500	9,20
25	16000	0,028	166	3300	13,8
35	13000	0,092	186	3000	18,4
38	12000	0,198	206	2800	23,8
42	10000	0,282	246	2300	28,4
50	8000	0,501	286	2000	41,4
60	6700	0,560	336	1800	48,5
70	5900	0,900	138	3800	13,2
80	5100	1,140	158	3500	18,3
85	4750	1,520	168	3300	26,2
90	4300	1,940	188	3000	31,0
105	4000	2,540	208	2800	52,0
115	3400	3,480	248	2300	71,0
135	3000	6,850	288	2000	108,0
136	3800	7,64	338	1800	156,0

¹⁾ For selection of coupling see page 123/124.

²⁾ The permissible displacement figures mentioned are maximum figures which must not arise at the same time. If radial, axial and angular displacements arise in parallel, the figures need to be reduced.

Technical data

Weights and mass moments of inertia						
Size	Hub ¹⁾ [kg] / [kgm ²]	Lamina set [kg] / [kgm ²]	NN ¹⁾ complete [kg] / [kgm ²]	NANA 1 ¹⁾ complete [kg] / [kgm ²]	NANA 2 ¹⁾ complete [kg] / [kgm ²]	NNZ ¹⁾ complete [kg] / [kgm ²]
20	0,13 / 0,00043	0,04 / 0,00002	0,3 / 0,00011	0,6 / 0,000204	–	0,4 / 0,000166
25	0,2 / 0,000116	0,08 / 0,00005	0,56 / 0,00028	0,9 / 0,000522	–	0,8 / 0,000414
35	0,6 / 0,00042	0,10 / 0,00010	1,2 / 0,00094	1,9 / 0,00158	–	1,6 / 0,00129
38	0,8 / 0,00073	0,20 / 0,00026	1,8 / 0,0017	2,8 / 0,00303	–	2,4 / 0,00247
42	1,1 / 0,00123	0,25 / 0,00040	2,4 / 0,0029	3,6 / 0,00482	–	3,1 / 0,00409
50	1,7 / 0,00291	0,46 / 0,0010	4,0 / 0,0068	6,2 / 0,0118	–	5,1 / 0,00932
60	1,9 / 0,00378	0,40 / 0,0012	4,2 / 0,0087	6,0 / 0,0141	5,8 / 0,0138	5,3 / 0,0120
70	2,8 / 0,00714	0,42 / 0,0016	6,0 / 0,016	8,6 / 0,0253	8,2 / 0,0242	7,5 / 0,0214
80	4,1 / 0,0134	0,72 / 0,0037	9,0 / 0,031	12,6 / 0,0476	12,0 / 0,0458	11,1 / 0,0410
85	5,1 / 0,0195	1,0 / 0,0065	11,2 / 0,046	16,2 / 0,0734	15,5 / 0,0711	14,8 / 0,0650
90	6,2 / 0,0282	2,3 / 0,0162	14,7 / 0,073	22,0 / 0,121	21,3 / 0,119	20,1 / 0,108
105	7,6 / 0,0414	2,2 / 0,0180	17,4 / 0,101	25,8 / 0,165	24,6 / 0,159	23,1 / 0,145
115	12,0 / 0,0899	4,0 / 0,0433	27,9 / 0,223	42,8 / 0,381	41,2 / 0,372	38,3 / 0,333
135	19,0 / 0,187	7,3 / 0,105	45,1 / 0,478	71,3 / 0,835	–	–
136	16,8 / 0,153	7,9 / 0,113	41,4 / 0,419	–	–	–
156	20,2 / 0,217	11,9 / 0,200	52,2 / 0,634	–	–	–
166	30,0 / 0,373	12,3 / 0,255	72,3 / 1,001	–	–	–
186	42,0 / 0,629	12,7 / 0,318	96,7 / 1,576	–	–	–
206	55,1 / 1,004	18,2 / 0,548	128,3 / 2,556	–	–	–
246	85,9 / 2,229	31,2 / 1,304	203,1 / 5,762	–	–	–
286	145,1 / 4,977	44,4 / 2,495	334,4 / 12,449	–	–	–
336	223,9 / 10,486	64,2 / 4,74	512,0 / 25,712	Mounting dimension E as indicated by the customer	Mounting dimension E as indicated by the customer	–
138	16,2 / 0,145	9,9 / 0,143	42,3 / 0,433	–	–	–
158	19,5 / 0,205	14,9 / 0,252	54,0 / 0,662	–	–	–
168	29,4 / 0,360	15,2 / 0,318	74,0 / 1,038	–	–	–
188	41,7 / 0,611	15,6 / 0,396	99,0 / 1,618	–	–	–
208	54,1 / 0,971	22,4 / 0,680	130,5 / 2,622	–	–	–
248	84,0 / 2,144	38,2 / 1,605	206,2 / 5,893	–	–	–
288	142,5 / 4,823	53,8 / 3,056	338,8 / 12,702	–	–	–
338	220,1 / 10,18	78,0 / 5,817	518,2 / 26,177	–	–	–

¹⁾ Hubs with max. bore

RADEX®-N
RIGIFLEX®-N
RIGIFLEX®-HP

Cylindrical bores

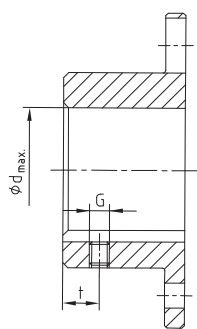

Standard hub 1.0 with keyway according to DIN 6885 sheet 1									
Size	d_{max}	G	t	T_A [Nm]	Size	d_{max}	G	t	T_A [Nm]
20	20	M5	6	2,0	105	105	M12	30	40,0
25	25	M5	8	2,0	115	115	M12	30	40,0
35	35	M6	15	4,8	135	135			
38	38	M6	15	4,8	136 / 138	135			
42	42	M8	20	10,0	156 / 158	150			
50	50	M8	20	10,0	166 / 168	165			
60	60	M8	20	10,0	186 / 188	180			
70	70	M10	20	17,0	206 / 208	200			
80	80	M10	20	17,0	246 / 248	240			
85	85	M10	25	17,0	286 / 288	280			
90	90	M12	25	40,0	336 / 338	330			
							On request of customer		

Backlash-free shaft-hub connections without feather key

Selection: In case of use in hazardous areas the clamping ring hubs must be selected in a way that there is a minimum safety factor of $s = 2$ between the peak torque (including all operating parameters) and the nominal torque and frictional torque of engagement of the coupling.

Clamping ring hub type 6.5
(clamping screws externally)

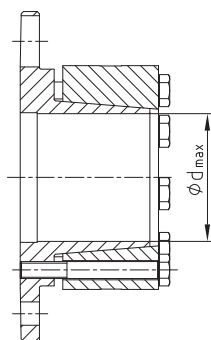

Clamping ring hub type 6.0
(clamping screws internally)

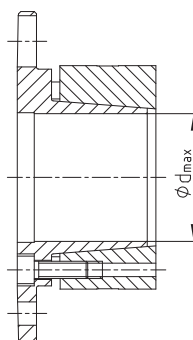

Design with CLAMPEX®
element type 603

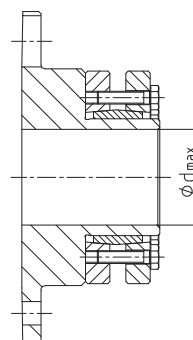

Standard types



- Standard types available from stock
- Single and double cardanic types
- Optionally available with frictionally engaged shaft-hub-connection
- Finish bore according to ISO fit H7, feather keyway according to DIN 6885 sheet 1 - JS9
- Ex -Approved and certified according to EC Standard 94/9/EC
- From size 136 screwing of laminas by means of clamping nut (see assembly instructions KTR-N 47112)

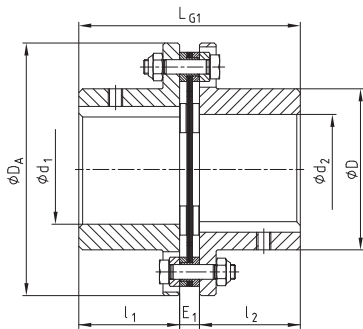

Type NN

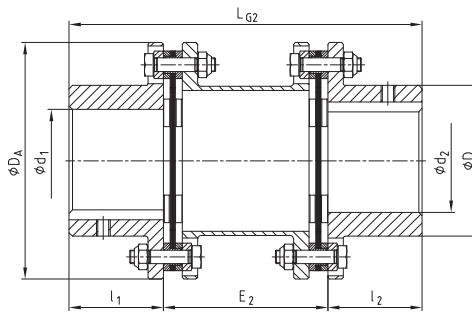

Type NANA 1

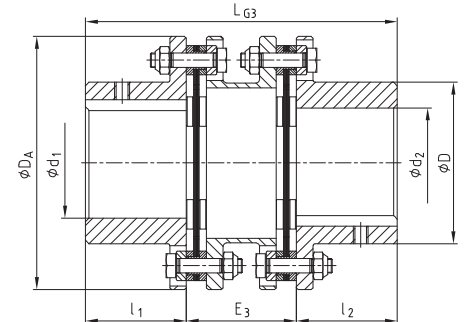

Type NANA 2

RADEX®-N Types NN, NANA 1, NANA 2										
Size	Max. finish bore	Dimensions [mm]								
	d ₁ /d ₂	D	D _A	l ₁ /l ₂	L _{G1}	E ₁	L _{G2}	E ₂	L _{G3}	E ₃
20	20	32	56	20	45	5	100	60	-	-
25	25	40	68	25	56	6	110	60	-	-
35	35	54	82	40	86	6	150	70	-	-
38	38	58	94	45	98	8	170	80	-	-
42	42	68	104	45	100	10	170	80	-	-
50	50	78	126	55	121	11	206	96	-	-
60	60	88	138	55	121	11	206	96	170	60
70	70	102	156	65	141	11	246	116	200	70
80	80	117	179	75	164	14	286	136	233	83
85	85	123	191	80	175	15	300	140	246	86
90	90	132	210	80	175	15	300	140	251	91
105	105	147	225	90	200	20	340	160	281	101
115	115	163	265	100	223	23	370	170	309	109
135	135	184	305	135	297	27	520	250	-	-
136	135	180	300	135	293	23				
156	150	195	325	150	327	27				
166	165	225	350	165	361	31				
186	180	250	380	185	401	31				
206	200	275	420	200	437	37				
246	240	320	500	240	524	44				
286	280	383	567	280	612	52				
336	330	445	660	330	718	58				
138	135	180	300	135	293	23				
158	150	195	325	150	327	27				
168	165	225	350	165	361	31				
188	180	250	380	185	401	31				
208	200	275	420	200	437	37				
248	240	320	500	240	524	44				
288	280	383	567	280	612	52				
338	330	445	660	330	718	58				

Ordering example	RADEX®-N 60	NANA 1	Ø50	Ø60
	Coupling size	Type	Finish bore d ₁	Finish bore d ₂

Standard types



- Standard types available from stock
- Single and double cardanic designs
- Furthermore available with frictionally engaged shaft-hub-connection
- Type NNZ (double-cardanic) for very short shaft distance dimensions
- Finish bore according to ISO fit H7, feather keyway according to DIN 6885 sheet 1 - JS9
- -Approved and certified according to EC Standard 94/9/EC

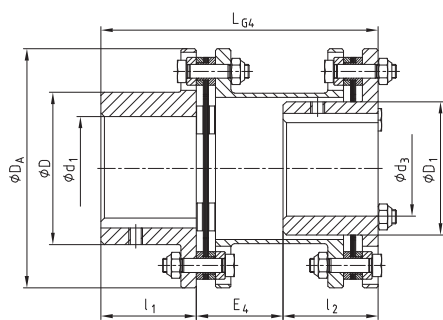

Type NENA 1

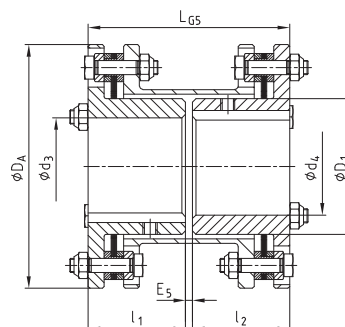

Type NENE 1

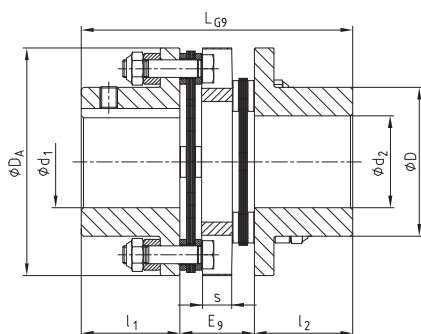

Type NNZ

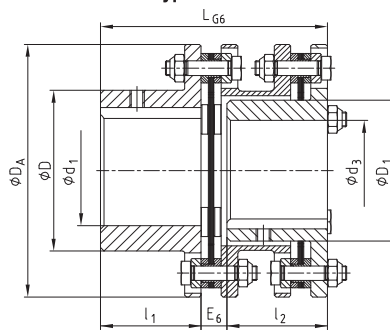

Type NENA 2

RADEX®-N Types NENA 1, NENE 1, NENA 2, NNZ

Size	Max. finish bore		Dimensions [mm]												
	d ₁ /d ₂	d ₃ /d ₄	D	D ₁	D _A	l ₁ /l ₂	L _{G4}	E ₄	L _{G5}	E ₅	L _{G6}	E ₆	L _{G9}	E ₉	
20	20	-	32	-	56	20	-	-	-	-	-	-	58	18	
25	25	-	40	-	68	25	-	-	-	-	-	-	70	20	
35	35	-	54	-	82	40	-	-	-	-	-	-	102	22	
38	38	-	58	-	94	45	-	-	-	-	-	-	118	28	
42	42	-	68	-	104	45	-	-	-	-	-	-	124	34	
50	50	-	78	-	126	55	-	-	-	-	-	-	144	34	
60	60	55	88	77	138	55	160	50	114	4	124	14	144	34	
70	70	65	102	90	156	65	190	60	134	4	144	14	166	36	
80	80	75	117	104	179	75	220	70	154	4	167	17	-	-	
85	85	80	123	112	191	80	232	72	164	4	178	18	-	-	
90	90	85	132	119	210	80	233	73	166	6	184	24	-	-	
105	105	90	147	128	225	90	263	83	186	6	204	24	-	-	
115	115	100	163	145	265	100	288	88	206	6	227	27	-	-	

Ordering example:

RADEX®-N 60	NENA 1	Ø50	Ø60
Coupling size	Type	Finish bore d ₁	Finish bore d ₂

Customized types



- Types as per customer requirements
- Type NANA 4 for shaft distance dimensions up to 6 m (please note the critical whirling speed)
- Type NNW with solid shaft (please note the critical whirling speed)
- Finish bore according to ISO fit H7, feather keyway according to DIN 6885 sheet 1 - JS9
- Ex-Approved and certified according to EC Standard 94/9/EC
- From size 136 screwing of laminas by means of clamping nut (see assembly instructions KTR-N 47112)

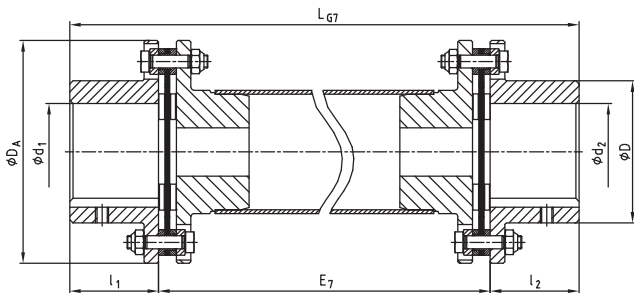

Type NANA 4

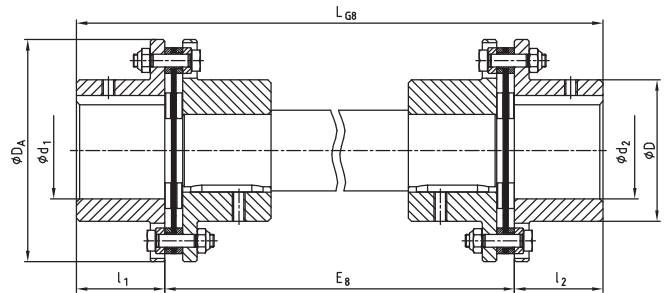

Type NNW

RADEX®-N Types NANA 4, NNZ and NNW								
Size	Max. finish bore	Dimensions [mm]						
	d ₁ /d ₂	D	D _A	l ₁ /l ₂	L _{G7}	E ₇	L _{G8}	E ₈
20	20	32	56	20				
25	25	40	68	25				
35	35	54	82	40				
38	38	58	94	45				
42	42	68	104	45				
50	50	78	126	55				
60	60	88	138	55				
70	70	102	156	65				
80	80	117	179	75				
85	85	123	191	80				
90	90	132	210	80				
105	105	147	225	90				
115	115	163	265	100				
135	135	184	305	135				
136	135	180	300	135				
156	150	195	325	150				
166	165	225	350	165				
186	180	250	380	185				
206	200	275	420	200				
246	240	320	500	240				
286	280	383	567	280				
336	330	445	660	300				
138	135	180	300	135				
158	150	195	325	150				
168	165	225	350	165				
188	180	250	380	185				
208	200	275	420	200				
248	240	320	500	240				
288	280	383	567	280				
338	330	445	660	300				

Ordering example:	RADEX®-N 60	NANA 4	Ø50	Ø60	2500
	Coupling size	Type	Finish bore d ₁	Finish bore d ₂	Shaft distance dimension

Standard series NANA 3 for pump drives according to API 610



- Series NANA 3 for pump drives, coupling according to API 610
- High balancing quality due to accurate manufacturing (AGMA class 9)
- Device to protect the spacer if the lamina breaks (see detail "X")
- Finish bore according to ISO fit H7, feather keyway according to DIN 6885 sheet 1 - JS9
- CE-Approved and certified according to EC Standard 94/9/EC
- From size 136 screwing of laminas by means of clamping nut (see assembly instructions KTR-N 47112)

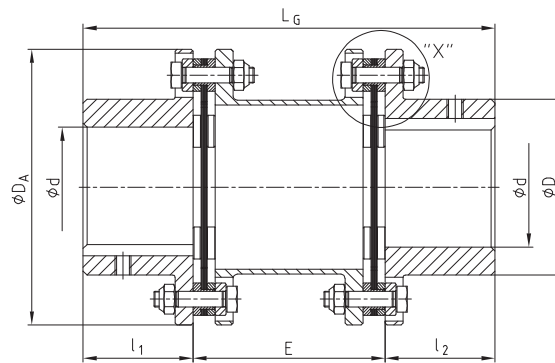

RADEX®-N Type NANA 3							
Size	Max. finish bore d	Dimensions [mm]				Perm. displacements	
		D	D _A	E ^{Standard} ¹⁾	l ₁ /l ₂	Angle each lamina [°]	Axial [mm]
42	42	68	104	100	45	1,0	2,8
50	50	78	126	140/180	55	1,0	3,2
60	60	88	138	100/140/180/250	55	1,0	2,0
70	70	102	156	100/140/180	65	1,0	2,2
80	80	117	179	100/140/180/250	75	1,0	2,6
85	85	123	191	100/140/180/250	80	1,0	2,3
90	90	132	210	140/180/250	80	1,0	2,0
105	105	147	225	250	90	1,0	2,4
115	115	163	265	250	100	1,0	2,8
135	135	184	305	250	135	1,0	3,5
136	135	180	300		135	0,7	3,7
156	150	195	325		150	0,7	4,2
166	165	225	350		165	0,7	4,5
186	180	250	380		185	0,7	4,8
206	200	275	420		200	0,7	5,2
246	240	320	500		240	0,7	6,0
286	280	383	567		280	0,7	6,7
336	330	445	660		330	0,7	7,5
138	135	180	300	acc. to customer's specifications	135	0,5	2,6
158	150	195	325		150	0,5	2,8
168	165	225	350		165	0,5	3,0
188	180	250	380		185	0,5	3,2
208	200	275	420		200	0,5	3,5
248	240	320	500		240	0,5	4,0
288	280	383	567		280	0,5	4,5
338	330	445	660		330	0,5	5,0

¹⁾ Other distance dimensions E available on request.

Detail "X"

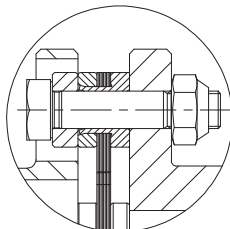

Safety gear of the spacer:
The lamina sets have a sleeve in order to secure the spacer if the lamina breaks.

Ordering example:	RADEX®-N 60	NANA 3	Ø50	Ø60	140
	Coupling size	Type	Finish bore d ₁	Finish bore d ₂	Shaft distance dimension

Corrosion-resistant type for big shaft distance dimensions



- All steel parts made of stainless material
- Composite tubes are conglutinated with the flanges and radially bolted in addition
- Spacer sealed against environmental influences (e. g. penetration of moisture into the glued joint)
- On request also available with brake disk made of stainless material
- ATEX release possible

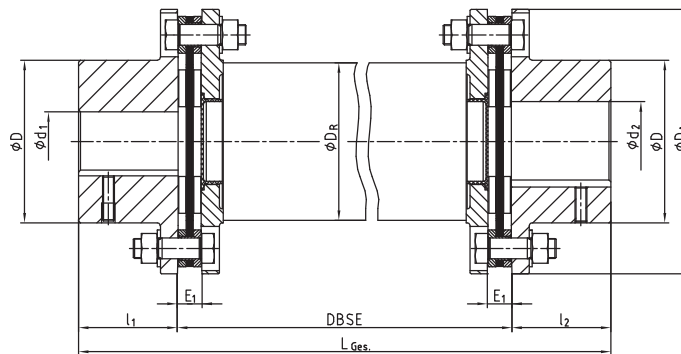

RADEX®-N Type NANA 4 CFK												
Size	Torque [Nm] ¹⁾		Dimensions [mm]								Composite tube D_P	max. DBSE ²⁾ with 1500 min ⁻¹
	T _{KN}	T _{K max}	D _A	d ₁ /d _{2 max.}	D	l ₁ /l ₂	E ₁	DBSE	L _{Ges.}			
70	800	1600	149	70	102	65	11	acc. to customer's specifications	l ₁ + l ₂ + DBSE	95	3500	
85	1800	3600	184	85	123	80	15			117	3900	
90	2500	5000	200	90	135	80	15			128	4100	
115	4500	9000	253	115	163	100	23			160	4600	

¹⁾ For selection of coupling see page 123/124.

²⁾ For higher speeds or bigger shaft distance dimensions please consult with KTR's engineering department (+49 5971 798-484). The above-mentioned characteristic figures (e. g. max. DBSE) can be varied by Composite tubes optimized for the application.

Particularly the steel lamina couplings are well suited for applications with especially large distance dimensions between the drive and the driven side (e. g. cooling towers, ventilators etc.) due to their design. In order to be able to realize high speeds with large distance dimensions, RADEX®-N couplings with intermediate shafts made of glass fiber or carbon fiber reinforced nylon (GRP or CFRP) are used, if necessary.

Ordering example:	RADEX®-N 85	NANA 4 CFK	Ø60	Ø70	3000
	Coupling size	Type	Finish bore d ₁	Finish bore d ₂	Shaft distance dimension

Description of coupling

RIGIFLEX®-N couplings are used on such applications which require a reliable and maintenance-free torque transmission with shaft displacement at the same time.

RIGIFLEX®-N was developed specifically for pump drives. This coupling system corresponds to the regulations of API 610 and may be supplied in accordance with API 671 optionally. (API = American Petroleum Institute)

Torques from 60 Nm to 280.000 Nm are available in 23 sizes for an optimum adjustment to the different applications.



RIGIFLEX®-N laminas

RIGIFLEX®-N laminas are waisted lamina sets arranged in layers. They are connected to the hubs or flanges, respectively, in an absolutely backlash-free fit by means of positive-locking set screws.

The number of the layers of individual laminas allows to vary torques, displacement figures and stiffness for special designs.

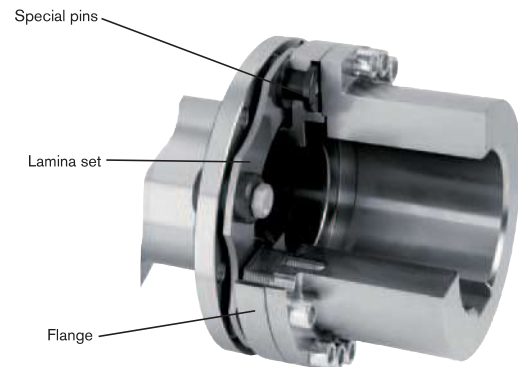

Protecting the spacer

Since our main idea with the development of RIGIFLEX®-N was to comply with the standards of API 610 and API 671, the spacer is secured by a safety catch, too. In case that the laminas break the spacer remains within the coupling. In general the removable part is supplied along with a lamina set preassembled by the manufacturer.

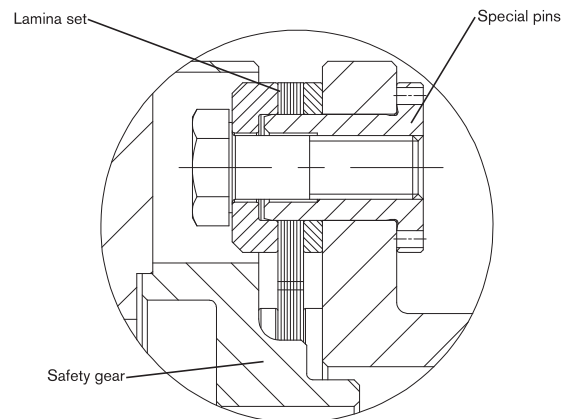

Explosion protection use

RIGIFLEX®-N couplings are suitable for the use in drives in hazardous areas. The couplings are certified and confirmed according to EC standard 94/9/EC (ATEX 95) as units of category 2G/2D and thus suitable for the use in hazardous areas of zone 1, 2, 21 and 22. Please read through our information included in the respective Type Examination Certificate and the operating and mounting instructions at www.ktr.com.



Technical data

The following lamina types are distinguished with RIGIFLEX®-N:

Size 35 – 65
(4 hole lamina)

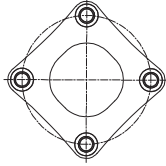

Size 75 – 160
(6 hole lamina)

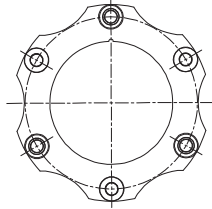

Size 166 – 406
(6 hole lamina)

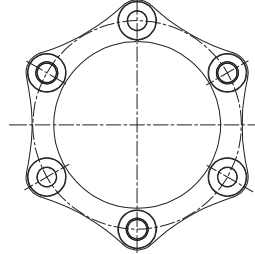

Size 168 – 408
(8 hole lamina)

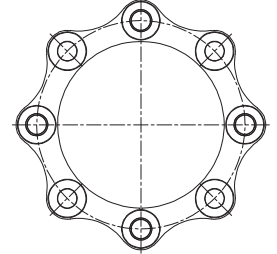

Torques and displacements											
Size	Lamina type	Torques [Nm]			Permissible displacements						
		TKN	TK max.	TKW	Angular ± Kw ¹⁾ [°]	Axial ± Ka [mm]	Radial ± Kr [mm]				
							E=100	E=140	E=180	E=200	E=250
35	4 hole lamina	130	260	65	0,7	1,2	0,90	1,40	–	–	–
50		270	540	135	0,7	1,4	0,77	1,26	–	–	–
65		550	1100	275	0,7	1,5	0,75	1,23	1,72	–	–
75		1100	2200	550	0,7	1,8	0,73	1,22	1,71	–	–
85		1900	3800	950	0,7	2,1	–	1,14	1,62	1,87	2,48
110		3500	7000	1750	0,7	2,4	–	1,05	1,54	1,78	2,39
120		5750	11500	2875	0,7	2,6	–	1,00	1,49	1,73	2,35
140	10500	21000	5250	0,7	3,3	–	–	–	1,55	2,16	
160	16000	32000	8000	0,7	3,8	–	–	–	–	1,99	
166	6 hole lamina	19000	38000	9500	0,7	3,7	Mounting dimension E as indicated by the customer				
196		22500	45000	11250	0,7	4,2					
216		32000	64000	16000	0,7	4,5					
256		52500	105000	26250	0,7	5,2					
306		86000	172000	43000	0,7	6,0					
346		135000	270000	67500	0,7	6,7					
406		210000	420000	105000	0,7	7,5					
168	8 hole lamina	25000	50000	12500	0,5	2,6	Mounting dimension E as indicated by the customer				
198		30000	60000	15000	0,5	2,8					
218		42500	85000	21500	0,5	3,0					
258		70000	140000	35000	0,5	3,5					
308		115000	230000	57500	0,5	4,0					
348		180000	360000	90000	0,5	4,5					
408		280000	560000	140000	0,5	5,0					

¹⁾ Angular displacement each lamina

If axial, angular and radial shaft displacement arises in parallel please note the following table:

Size	Permissible angular displacement								
	0	0,1	0,2	0,3	0,4	0,5	0,6	0,7	
	Permissible axial displacement								
35	1,20	1,00	0,85	0,74	0,60	0,40	0,20	0,00	
50	1,40	1,20	1,00	0,80	0,60	0,40	0,20	0,00	
65	1,50	1,29	1,07	0,86	0,64	0,43	0,22	0,00	
75	1,80	1,54	1,29	1,03	0,77	0,52	0,26	0,00	
85	2,10	1,80	1,50	1,20	0,90	0,60	0,30	0,00	
110	2,40	2,06	1,71	1,37	1,03	0,69	0,34	0,00	
120	2,60	2,23	1,86	1,48	1,11	0,74	0,37	0,00	
140	3,30	2,83	2,36	1,88	1,41	0,94	0,47	0,00	
160	3,80	3,26	2,71	2,17	1,63	1,09	0,54	0,00	
166	3,70	3,17	2,64	2,12	1,59	1,06	0,53	0,00	
196	4,20	3,60	3,00	2,40	1,80	1,20	0,60	0,00	
216	4,50	3,86	3,21	2,57	1,93	1,29	0,64	0,00	
256	5,20	4,46	3,71	2,97	2,23	1,49	0,74	0,00	
306	6,00	5,14	4,29	3,43	2,57	1,72	0,86	0,00	
346	6,75	5,79	4,82	3,86	2,89	1,93	0,96	0,00	
406	7,50	6,43	5,36	4,28	3,21	2,14	1,07	0,00	
168	2,60	2,08	1,56	1,04	0,52	0,00	–	–	
198	2,80	2,24	1,68	1,12	0,56	0,00	–	–	
218	3,00	2,40	1,80	1,20	0,60	0,00	–	–	
258	3,50	2,80	2,10	1,40	0,70	0,00	–	–	
308	4,00	3,20	2,40	1,60	0,80	0,00	–	–	
348	4,50	3,60	2,70	1,80	0,90	0,00	–	–	
408	5,00	4,00	3,00	2,00	1,00	0,00	–	–	